

Through beam fiber optics

FSE 200C2004

dimension drawing

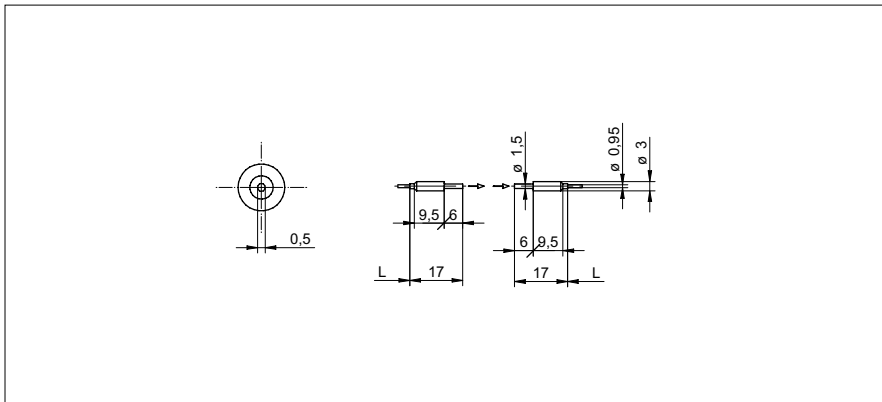

general data

particular characteristics	standard
type	through beam sensor
actual range Sb	340 mm
response time / release time	0,05 ... 5 ms
type of head (fiber optic cable)	cylindrical smooth (axial)
width / diameter (head)	3 mm
height / length (head)	17 mm
material (head)	aluminum
bending radius	8 mm
cable jacket diameter	0,95 mm
material cable jacket	PE
material (fiber optic cable)	plastic
length (fiber optic cable)	2000 mm
operating temperature	-30 ... +70 °C

photo



Sensing distance/response time:

For the definitive sensing distance/response time please see table below "fitting fiber optic sensors".



fitting fiber optic sensors	actual range Sb (0,05 ms)	actual range Sb (0,25 ms)	actual range Sb (1 ms)	actual range Sb (5 ms)
FVDK 67 (standard version)	40 mm (HS)	-	290 mm (nL)	340 mm (HP)
FVDK 67 (2 adjustable outputs)	40 mm (HS)	-	290 mm (nL)	340 mm (HP)
FVDK 67 (master/slave)	40 mm (HS)	-	290 mm (nL)	340 mm (HP)
FVDK 66 (standard version)	-	70 mm (FT)	125 mm (nL)	-
FVDK 66 (master/slave)	-	70 mm (FT)	125 mm (nL)	-
FVDK 22	-	-	100 mm (nL)	-
FVDK 12	-	-	100 mm (nL)	-
FVDK 12 (fast version)	94 mm (HS)	-	-	-
FVDK 10	-	-	50 mm (nL)	-
FWDK 84 (analog output)	-	-	28 mm (nL)	-

operating modes
 HS High Speed
 FT fast
 nL Standard
 HP High Sensitivity