



Vision Sensors

The Perfect Solution for Accurate Inspection

Vision Sensors

Quality drives manufacturing competitiveness.

It's hard to earn market trust without product quality, even with advanced technology and productivity. Quality is the foundation of customer trust and the company's reputation.

Manufacturers are seeking faster and more accurate ways to ensure quality and using vision sensor inspection has become one of the key solutions.

Vision sensors determine the shape, size, characters, and patterns of target objects as the industrial camera. Autonics vision sensors distinguish good products from defects in real time to enhance productivity and quality on production lines.

Vision sensors detect even the most subtle defects invisible to the human eye. Hundreds or thousands of parts per second can be inspected reliably, ensuring consistent productivity and quality.

The Autonics VG2 series offer advanced yet simplified quality inspection features, featuring high-resolution imaging, auto-tuning (focus, brightness, and exposure), OCR/OCV, color identification, alignment-shape/corner, and more. The VG2 series significantly enhance inspection accuracy and user convenience.

Experience a smarter quality-driven manufacturing with the Autonics VG2 series.



Accurate Capture, Clear Image

Simplified Setup and Precise Inspection in any Environment

The VG2 series are equipped with built-in LED lighting and lenses, and users can replace the lighting, filters, and polarizing filter covers for flexible adaptation to object characteristics, reflections, and background conditions. Eight internal lightings enable accurate shooting even in low or uneven lighting.



Accurate Capture of Fast-moving Targets

The VG2 series capture high-speed objects precisely with a global shutter system, free from distortion or residual blur. This prevents image smearing or displacement on production lines, ensuring reliable inspection results.

Accurate Detection with 1.2MP Resolution

The VG2 series capture clear and reliable images at 1.2MP (1,280 × 960) resolution and up to 45 fps, providing accurate inspection of fast-moving targets. It guarantees stable inspection quality on high-speed production lines. (* 0.3MP model is available up to 60 fps.)

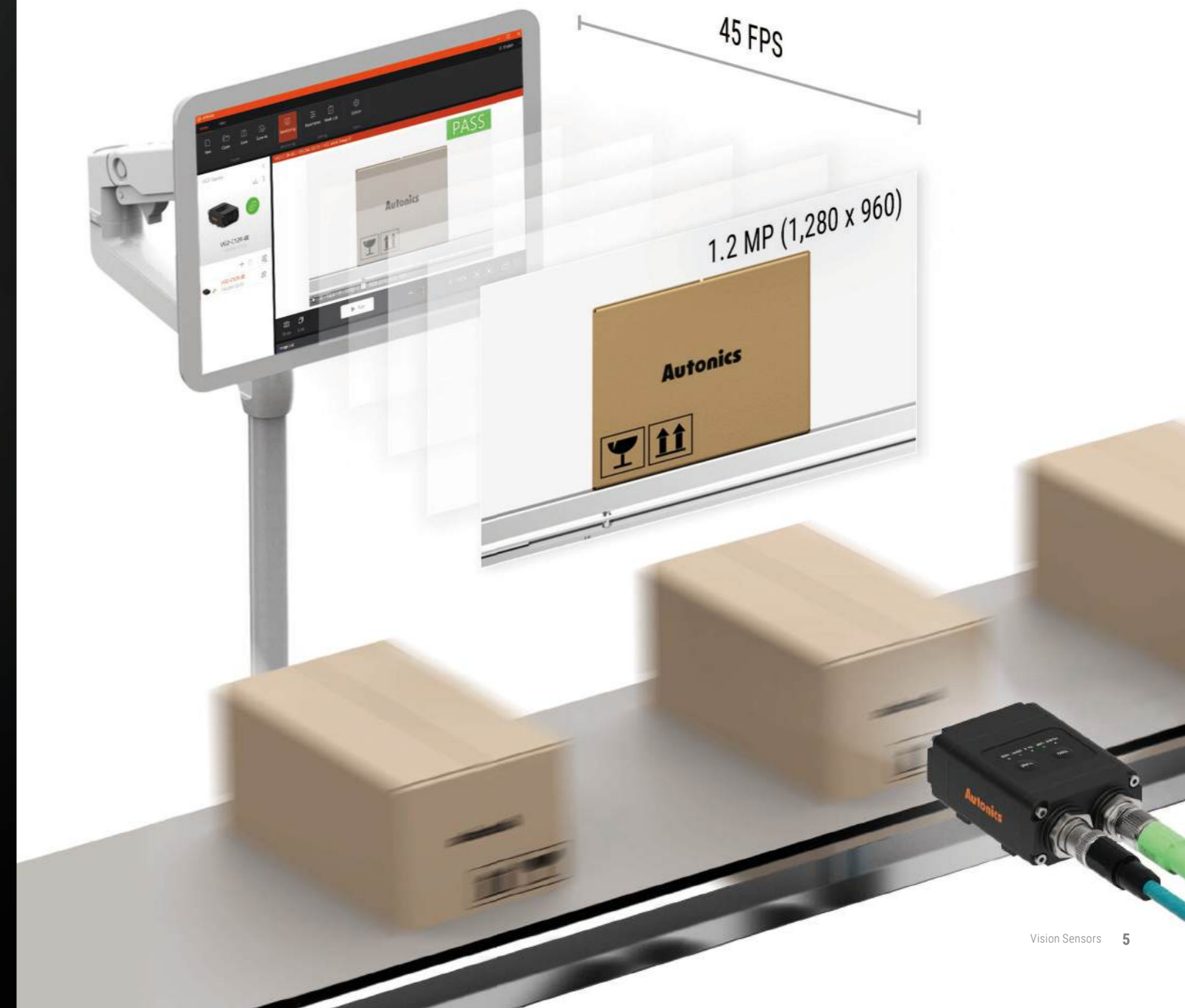

Simple for Everyone, From Installation to Operation

Auto-focus for up to 64 Groups

The auto-focus allows focus settings by work group, with flexible adjustment without reinstallation when changing groups. The VG2 series support up to 64 groups, reduce setup time and enable stable image acquisition.

Work Group 1

Work Group 2

Work Group 64

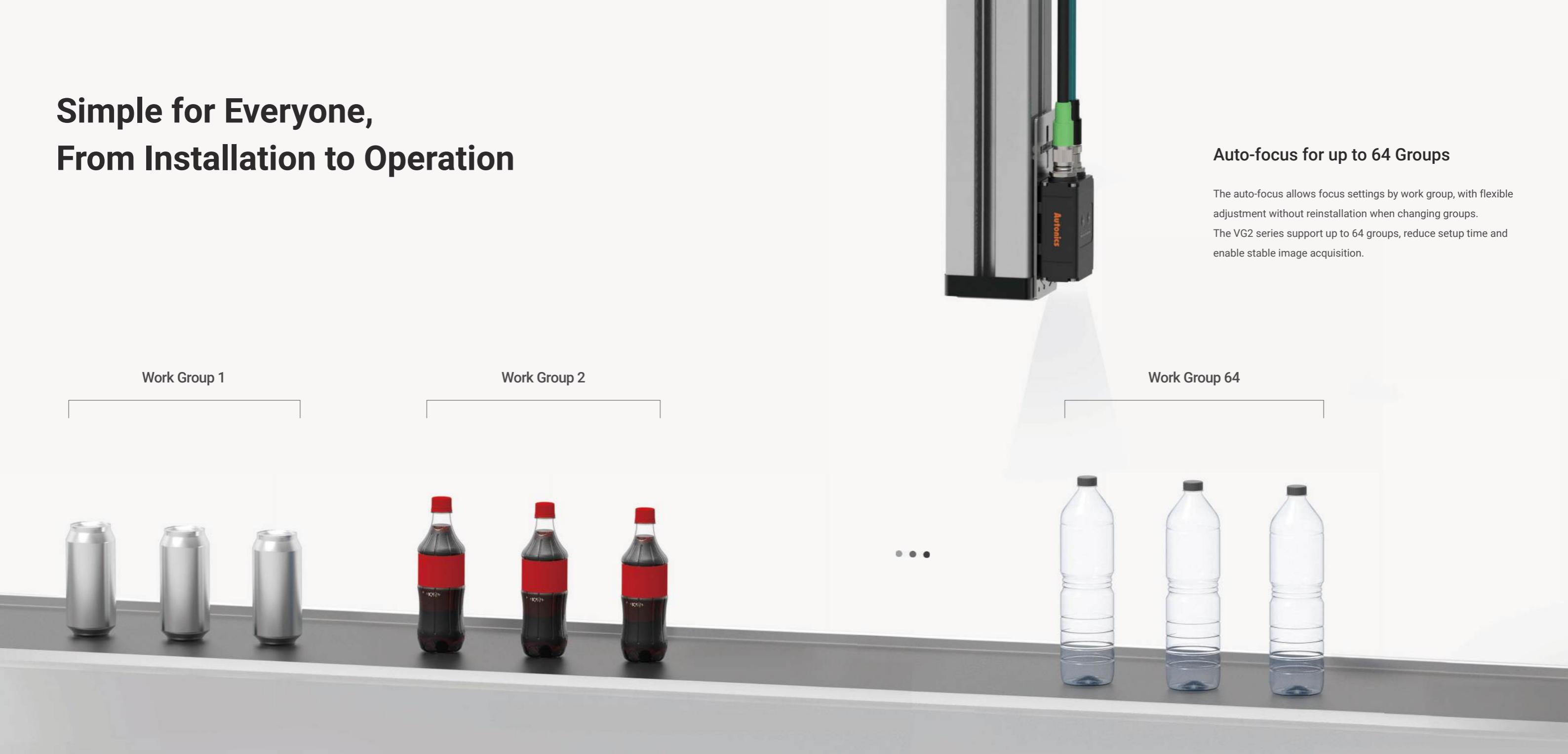

Auto-tuning of Focus, Brightness, and Exposure

VG2 series provide an auto-tuning function, allowing for the automatic setting of optimized focus, brightness, and exposure. After setting the detection target, users press the focus adjustment button to obtain clear images. Additionally, the brightness and exposure time are automatically adjusted according to the inspection environment to ensure stable image quality.

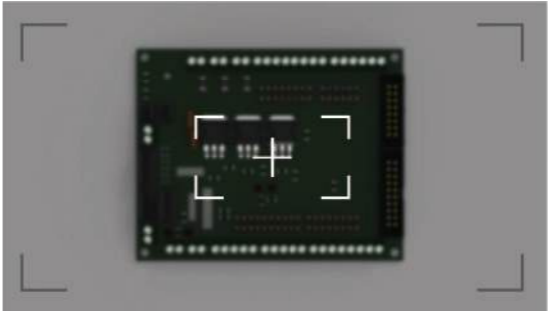

Auto Tune



Optimized Focus, Brightness, and Exposure!

Compact, Slim Design Optimized for any Installation Space

Compact design (W51.6 × H28.7 × D70.2 mm) with an integrated structure aligns the lens and connector on the same axis increase installation space efficiency. It fits easily into tight spaces such as multi-axis robots or narrow inspection areas, reducing interference and simplifying wiring, and ensuring user convenience.



Ribbon Menu
Displays the functions of atVision software

Image Viewer
Displays images of connected devices

Device Information
Displays the Device Information

Image List
Displays the image list

Parameter
Displays the parameter setting list

Dedicated Software 'atVision'

Easy setup and management of various inspection conditions are possible with the dedicated software, atVision. The easy-to-use graphical user interface lets users set parameters. The software can be used to monitor inspection data in real time and to build advanced inspection environments through detailed condition settings. Visual confirmation and history management ensure stable inspection quality.

Perfect Inspection Functions



Optical Character Recognition (OCR)

Recognizes characters from the input ROI (region of interest) and compares with the correct string.

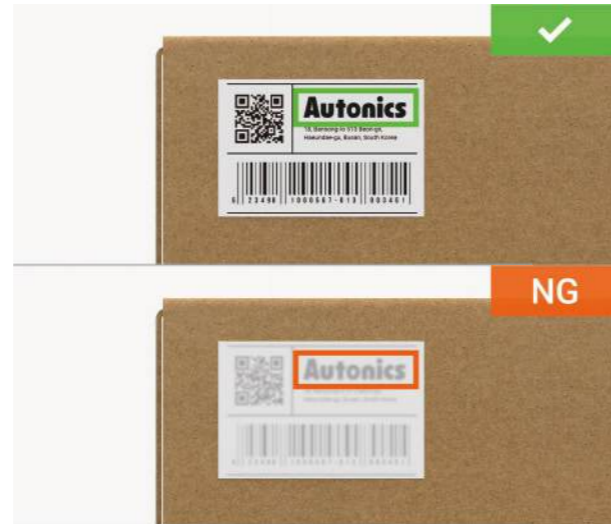

Optical Character Verification (OCV)

Compares the registered and input characters to verify completeness and print quality.



Alignment-Shape

Inspects by comparing the registered image features with the shape of the input image, searching the location of similar patterns, and obtaining the location and rotation angle information of the searched pattern.

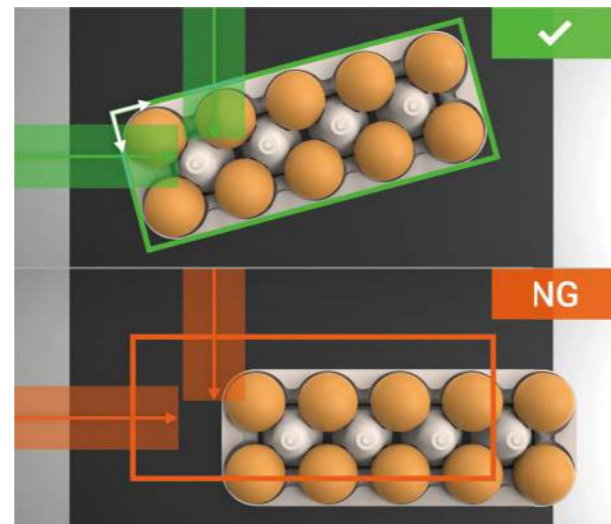

Alignment-Corner

Compares and inspects corrected position and angle of the input image by using the correlation and angles of the registered.

Various Inspection Features and Optimal Results

The vision sensors provide various inspection functions including object identification, object counting, length, angle, shape comparison, alignment, OCR/OCV to enable precise inspection. This enables precise inspection across various targets and conditions, ensuring high-quality results in any field environment.

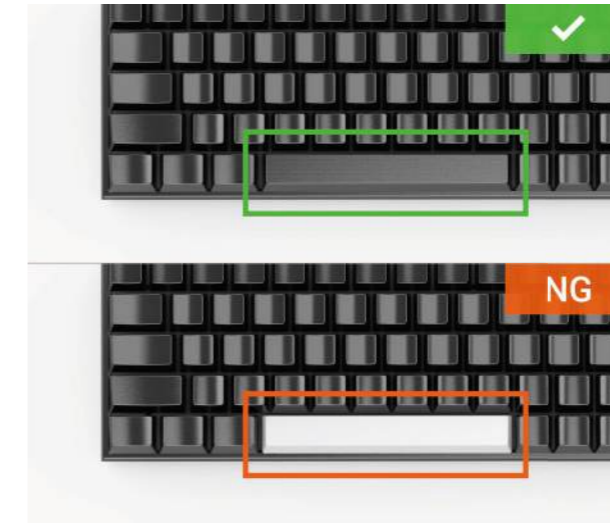

Brightness

Inspects the brightness of the captured image's ROI in reference to the average brightness of the registered image's ROI.

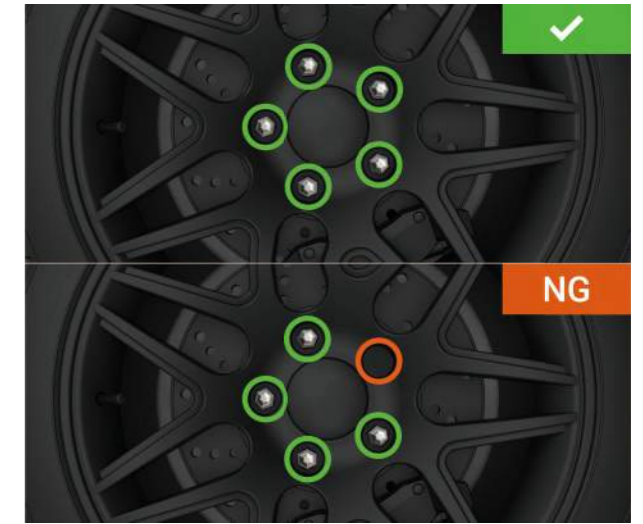

Contrast

Inspects the contrast of the captured image's ROI in reference to the contrast of the registered image's ROI.



Area

Compares the ROI size of the registered and input images.



Edge

Compares the edge location and angle in the registered and input images within the same area.

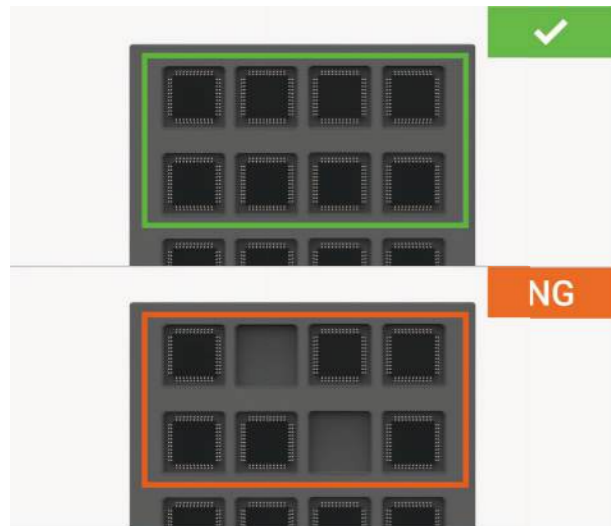

Shape Comparison

Inspects the shape of the captured image in reference to the shape of the registered image.

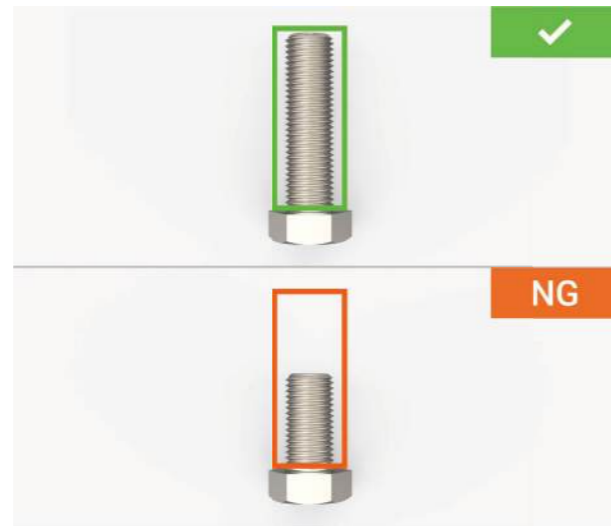

Length

Inspects the captured image in reference to the length set by the user between two edges of the registered image.

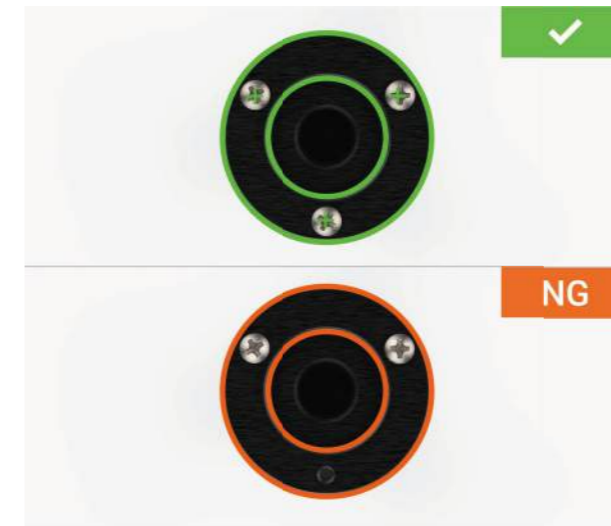

Object Counting

Inspects the number of objects in the captured image's ROI in reference to the registered number of objects in the registered image's ROI.

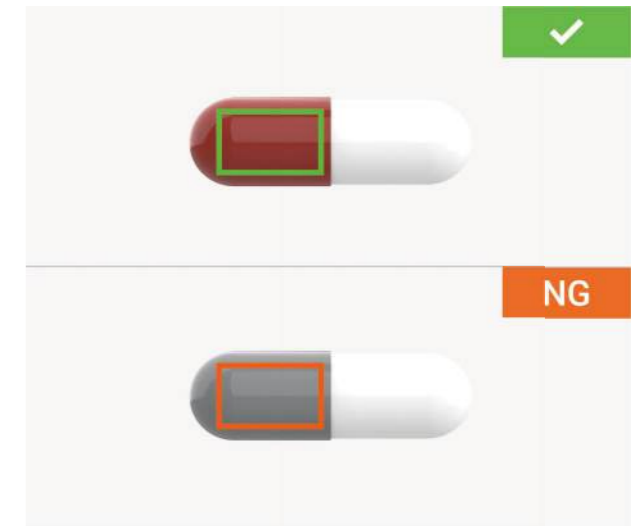

Color Identification

Inspects the color of the captured image's ROI in reference to the color of the registered image's ROI.



Angle

Inspects the captured image in reference to the angle set by the user between two edges of the registered image.

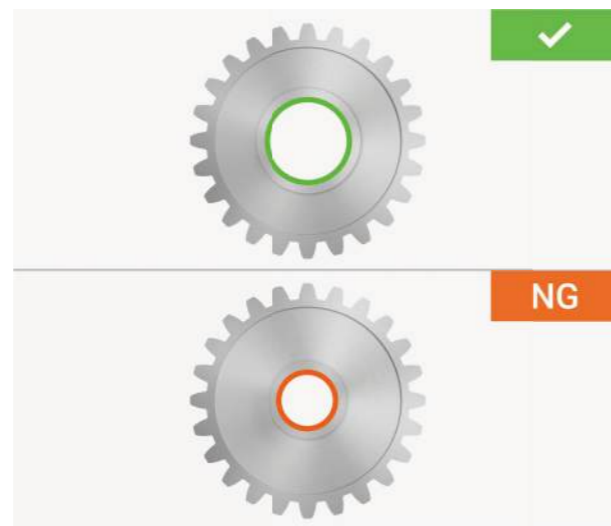

Diameter

Inspects by comparing the input image, based on circles detected within the user-registered annulus* region.

* Annulus: A donut-shaped figure formed by an inner and outer radius centered around a common midpoint.

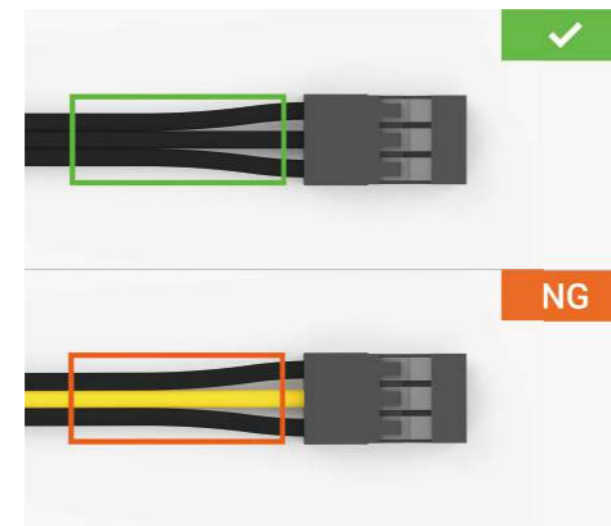

Area of Color

Inspects the color area size within the ROI of the registered and input images.



Object of Color Counting

Inspects the number of specific colored objects in the captured image's ROI in reference to the registered number of colored objects in the registered image's ROI.

Flexible Scalability and Durability for any Environment

IP66, IP67, IP69K Protection Structures

The VG2 Series are designed to meet IP66, IP67, and IP69K protection ratings, maintaining stable performance in industrial environments exposed to dust, moisture, or high-pressure cleaning. Durability and reliability ensure stable operation in challenging conditions such as dusty production lines, food and beverage facilities with frequent water exposure, and sanitary areas requiring high-temperature, high-pressure cleaning.

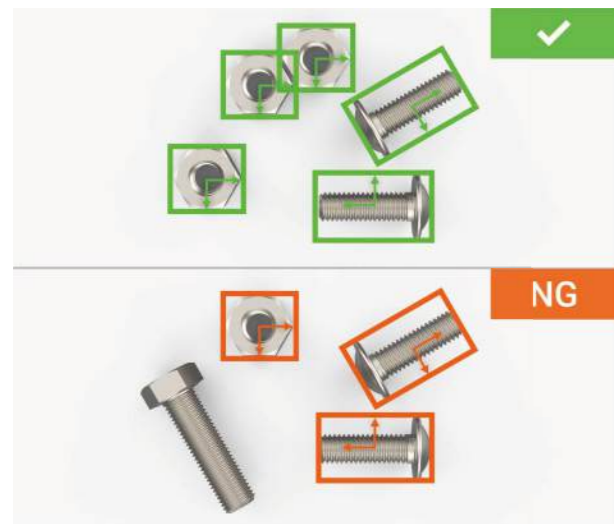

Multi-position Inspection

Compare the registered images with the input image to detect the presence and positions of multiple instances.

Management of Inspection Results and History

The VG2 Series enable centralized management of inspection data by transferring result images to an FTP server. Users can manage the results history collectively with the server without individual saving or analysis. Also, users can check the measurement results in real time through Gigabit Ethernet communication. Vision sensors enable immediate detection of defects or anomalies and provide stable quality with improved production efficiency.

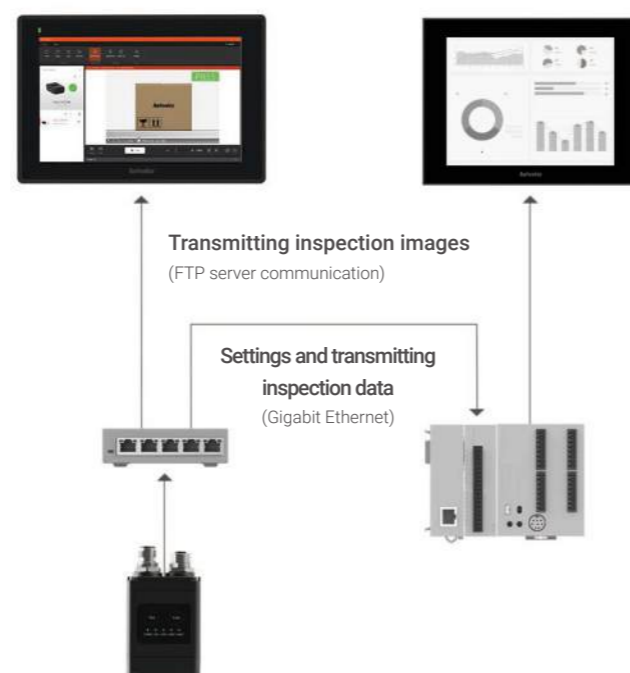

Flexible Adaptation with Sold Separately Options

Various sold separately options, including brackets, Ethernet connector covers, lighting, polarizing covers (8mm, 16mm), and color filters (red/blue), allows flexible setup to meet the specific requirements of any work environment.



Sold Separately

Type	Model	Product
Bracket	BK-VG2-A	
	BK-VG2-B	
Ethernet connector protection cover	P96-M12-1	
Polarizing cover	CVR-8P-VG2	
	CVR-16P-VG2	
Light	LM-W-8-VG2	
	LM-R-8-VG2	
	LM-B-8-VG2	
Filter	FL-B-VG2	
	FL-R-VG2	

Type	Model	Product
Cable	M12 connector cable (C□D12-□, C□DM12-□-A)	
	M12 connector communication cable (C□M8-□PR(-A), C□8-□PR(-A))	
Industrial PC	APC Series	

Vision Sensors Applications

Autonics vision sensors are applied in fields including food and beverage, packaging, pharmaceuticals, semiconductors, printing, and automotive manufacturing, providing precise inspection performance and easy operation as a perfect solution for improving manufacturing quality.

Vision sensors can identify defects in the production, monitor production lines, and precisely track and categorize components reducing defect rates and stabilizing quality.

Vision sensors are used across various industries, including food and beverage packaging, pharmaceuticals, semiconductors, printing, and automotive manufacturing. Autonics is dedicated to delivering optimal inspection solutions that enhance manufacturing quality through meticulous inspection and user-friendly operation.

1. Medical/Pharmaceutical Industry

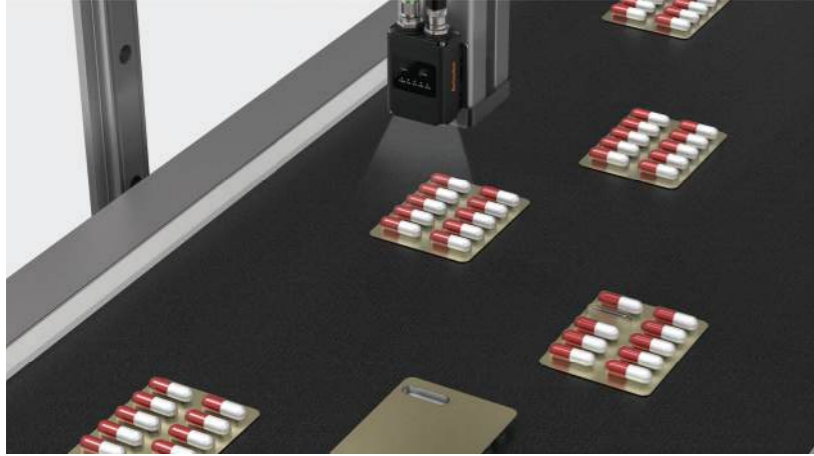

1-1. Pharmaceutical Drugs Production Line

Vision sensors are used to identify the number of pills, presence or absence of pills, or defects in packaging of medical supplies.

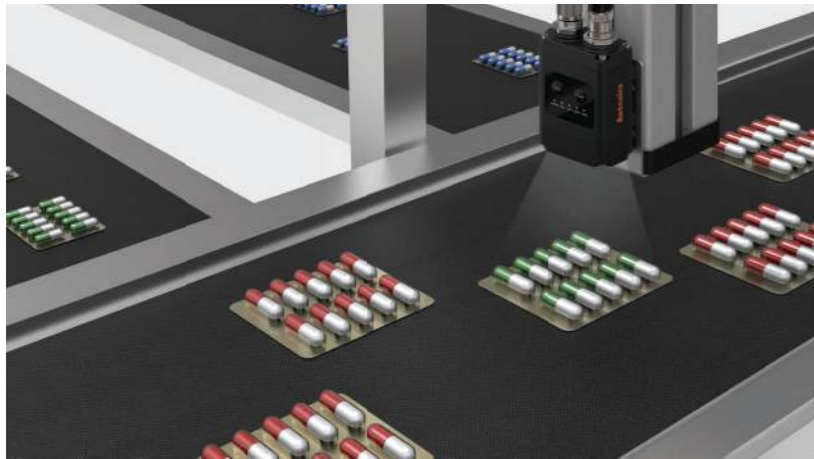

1-2. Pharmaceutical Drugs Transfer Line

Color type vision sensors are used to identify different color pills within packages.

2. Medical Equipment Industry



2-1. Syringes Assembly Line

Vision sensors are used to identify presence, absence, or defects of rubber packing in syringes during manufacturing.

3. Semiconductor Industry



3-1. PCB Transfer Line

Color type vision sensors are used to identify colors of diodes and capacitors on PCB boards during manufacturing process.



3-2. Semiconductor Parts Transfer Line

Vision sensors are used to identify the presence or absence of parts for defects during semiconductor transfer lines.

4. Printing Industry

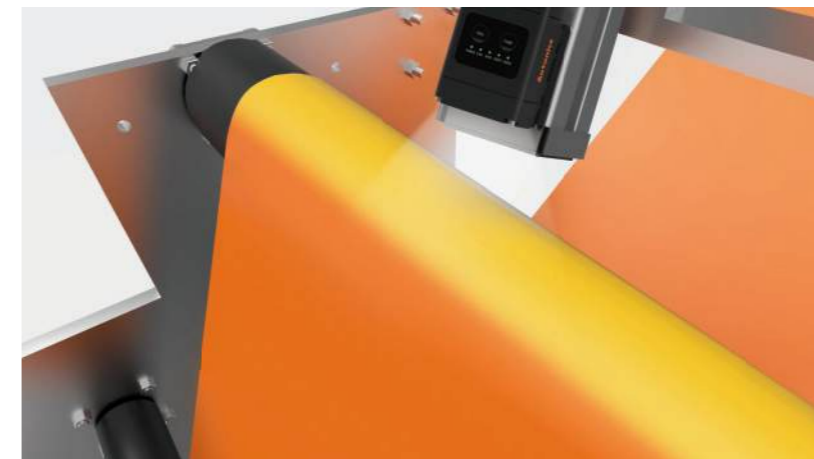

4-1. Printing Paper Transfer Line

Color type vision sensors are used to identify the color of printing paper during manufacturing and packaging processes.

5. Injection Molding Industry



5-1. Plastic Container Manufacturing Line

Visions sensors are used to identify errors in the shape of screw threads during injection molding process.

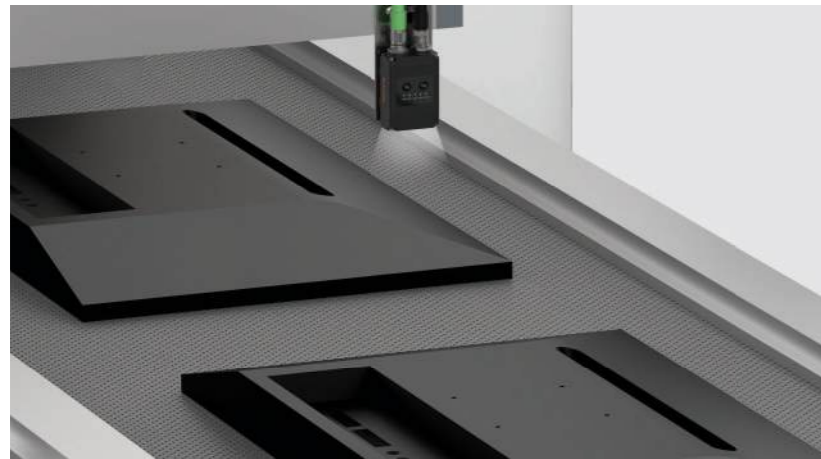

5-2. Monitor Assembly Transfer Line

Visions sensors are used to identify the molding status of monitors in manufacturing lines, including the number of holes, size, etc.

6. Logistics Industry



6-1. Shipping Transfer Line

Visions sensors are used to identify box sizes on shipping conveyor belts.

7. Food Industry



7-1. Containers Transfer Line

Visions sensors are used to identify sealing status of food containers on conveyor belts.



7-2. Beverage Containers Packaging Line

Visions sensors are used to identify the presence of expiration date printing on packages.

8. Cosmetics Industry



8-1. Cosmetics Containers Transfer Line

Visions sensors are used to identify the printing status on cosmetics containers.

9. Automotive Industry



9-1. Automobile Parts Manufacturing Line

Visions sensors are used to identify the shape of car spark plugs in manufacturing lines.



9-2. Automobile Parts Manufacturing Line

Color type vision sensors are used to identify colors of relays in car fuse box manufacturing lines.



9-3. Automobile Parts Manufacturing Line

Visions sensors are used to identify the shape of car wheels in manufacturing lines.



9-4. Automobile Parts Manufacturing Line

Visions sensors are used to identify the diameter of holes in car engine blocks during manufacturing.

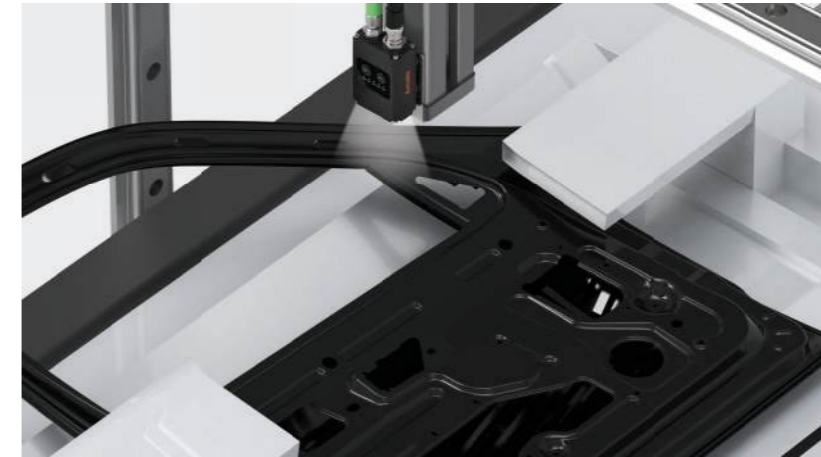

9-5. Press Process

Vision sensors are used to inspect the shape of automobile doors during manufacturing process.

10. Packaging Industry

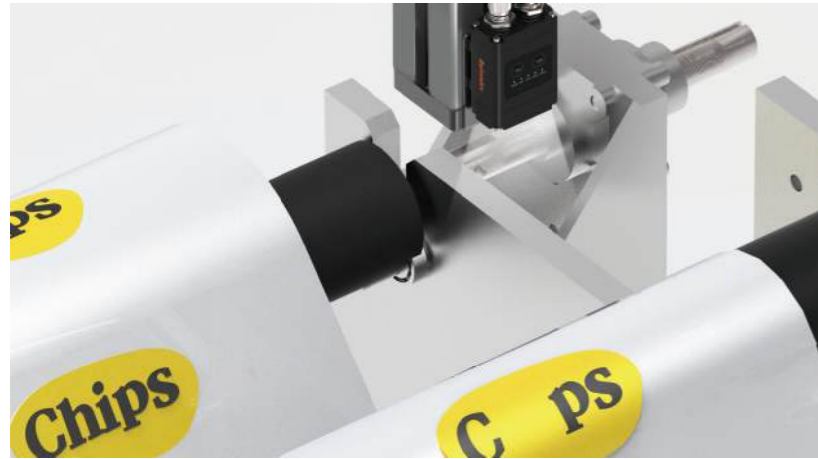

10-1. Inkjet Markers

Vision sensors are used to identify the printing status of marks on packaging paper from inkjet markers.



10-2. Pen Transfer Line

Color type vision sensors are used to identify the color of pens during manufacturing and packaging processes.



10-3. Engine Oil Containers Transfer Line

Color type vision sensors are used to identify the colors of engine oil containers on transport conveyor belts.



10-4. Beverage Containers Transfer Line

Vision sensors are used to identify the number of items in containers in packaging lines.

0.3M / 1.2M Monochrome / Color Vision Sensor (Internal illumination)

VG2 Series

Ordering Information

This is only for reference, the actual product does not support all combinations. For selecting the specified model, follow the Autonics website.



1 Image element

M: Mono CMOS
C: Color CMOS

3 Color of light

W: White
R: Red
B: Blue

2 Resolution

03: 0.3 MP (640 x 480 pixel)
12: 1.2 MP (1,280 x 960 pixel)

4 Effective focal length

Number: Effective focal length (unit: mm)

5 Communication

E: Ethernet (TCP/IP)

Specifications

Model	VG2-□□□-8E	VG2-□□□-16E
Effective focal length	8 mm	16 mm
Min. working distance	40 mm	
Image filter	Preprocessing, external filter (filter, polarizing cover)	
Image element	1/2.9 inch mono CMOS / color CMOS model, 3.45 x 3.45 μm pixel	
Shutter	Global shutter	
Exposure time	30 to 1,400,000 μs	
Lens type	f8 mm Board Lens	f16 mm Board Lens
	Liquid Lens (auto focus function)	
eMMC	8 GB	
DDR4	4 GB	
Inspection work group ⁰¹	64 (simultaneous inspection: 32)	
Light ON / OFF method	Pulse	
Trigger mode	Continuous, External Trigger, Manual, Ethernet, RS232	
Communication	Ethernet (TCP/IP, 10 / 100 / 1000 Base-T), Modbus (TCP, RTU)	
FTP trans. output	YES	
Certification	CE, RoHS, REACH	
Unit weight (package)	≈ 182 g (≈ 242 g)	≈ 202 g (≈ 262 g)

01) Up to 4 can be used when changing work groups through external input.

Model	VG2-□03□-□E	VG2-□12□-□E
Resolution	0.3 MP (640 x 480 pixel)	1.2 MP (1,280 x 960 pixel)
Max. No. of images collected per second ⁰¹	≤ 60 fps	≤ 45 fps

01) Based on the min. exposure, no trigger delay, inspection function / pre-processing not being configured and no Ethernet connection.

Power supply	24 VDC± 10 %
Current consumption	600 mA
Rated input signal	24 VDC± 10 %
Output signal	NPN-PNP open collector output setting (software)
Load voltage	24 VDC±
Load current	≤ 100 mA
Residual voltage	≤ 2 VDC±
Protection circuit	Output short overcurrent protection circuit, reverse voltage polarity protection circuit
Insulation resistance	≥ 100MΩ (500 VDC± megger)
Dielectric strength	500 VAC~ 50/60 Hz for 1 min.
Vibration	1.5 mm amplitude at frequency of 10 to 55 Hz in each X, Y, Z direction for 2 hours
Shock	300 m/s ² (≈ 30 G), 11 ms in each X, Y, Z direction for 3 times
Ambient temperature	0 to 45 °C, storage: -20 to 70 °C (non-freezing or non-condensation)
Ambient humidity	35 to 85%RH, storage: 35 to 85%RH (non-freezing or non-condensation)
Protection structure	IP66, IP67 (IEC standard), IP69K (DIN standard)
Connection	Connector type
Connector spec.	Power I/O: M12 12-pin, Ethernet: M12 8-pin (cable tightening torque: 0.4 N m)
Material	Case: Die-cast Aluminum Housing, Window: Glass, Gasket: Silicon

Unit Descriptions

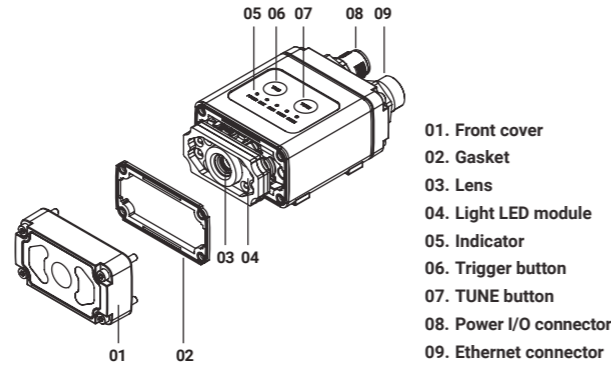

- 01. Front cover
- 02. Gasket
- 03. Lens
- 04. Light LED module
- 05. Indicator
- 06. Trigger button
- 07. TUNE button
- 08. Power I/O connector
- 09. Ethernet connector

Indicator

Indicator	Color	Name	Function
POWER	Green	Power indicator	Turns ON when power is supplied.
LINK	Green	Ethernet connection indicator	Turns ON in Ethernet communication status.
DATA	Green	Data transmit indicator	Flashes when data is transmitted between product and PC.
USER 1	Green	User setting indicator	Turns ON or flashes in operation of inspection complete, inspection result (PASS, FAIL), external trigger, alarm, and product work.
USER 2	Red		

Software

Download the installation file and the manuals from the Autonics website.

• atVision

The program allows setting of vision sensor parameters and management of monitoring data such as inspection status and status information.

[atVision]

■ Basic setting

- Camera setting
- Network setting
- I/O setting
- Advanced setting

■ Inspection function

Function	Descriptions
Alignment Shape	Compares the registered shape with the input image to detect the presence and position of the shape.
Alignment Corner	Compares the intersection of two registered edge lines with the input image to detect the presence of edges and the position of the intersection.
Brightness	Inspects the average brightness of the region.
Contrast	Inspects the contrast of the object.
Shape Comparison	Compares the registered shape with the input image to evaluate similarity.
Color Identification	Inspects the average color of the object.
OCR	Detects and recognizes characters.
OCV	Inspects the legibility and quality of characters.
Multi-position Inspection	Compares the registered shapes with the input image to detect the presence and positions of multiple shapes.
Area	Inspects the size of the region.
Edge	Measures the angle and position of edges.
Diameter	Measures the diameter and circularity of the object.
Object Counting	Counts the number of objects.
Angle	Measures the angle between two edge lines.
Length	Measures the distance between two edges.
Color Area	Inspects the area size of colored objects.
Count of Colored Objects	Counts the number of colored objects.

Dimensions

• Unit: mm, For the detailed drawings, follow the Autonics website.

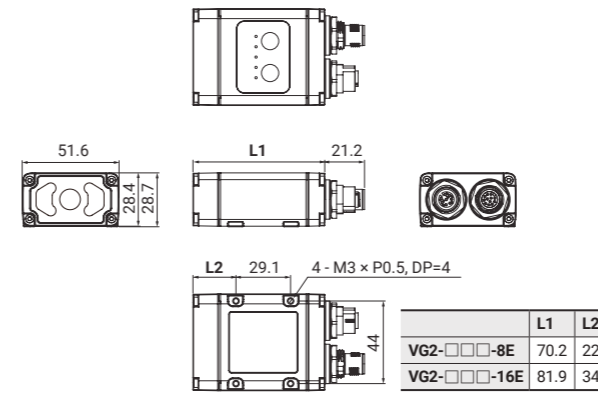

Sold Separately

[Polarizing cover]

CVR-□-VG2

Model	Appearance	Application Model
CVR-8P-VG2		VG2-□□□-8E
CVR-16P-VG2		VG2-□□□-16E

[Light]

LM-□-8-VG2

Model	Appearance	Color
LM-W-8-VG2		White
LM-R-8-VG2		Red
LM-B-8-VG2		Blue

[Filter]

FL-□-VG2

Model	Appearance	Color
FL-B-VG2		Blue
FL-R-VG2		Red
FL-W-VG2 ⁰¹⁾		Clear

01) When not using a color filter, use it to maintain the height of the entire fixture.

View product details



VG2



VC

Autonics

Global Network

Korea (Headquarters)

39, Magokjungang 5-ro 1-gil, Gangseo-gu,
Seoul, Republic of Korea, 07594
T 82-2-2048-1577
E sales@autonics.com

Germany

Autonics Germany Office
T 49-69-242-992-32
E germany@autonics.com

Japan

Autonics Japan Corporation
T 81-3-6435-8380 F 81-3-6435-8381
E ja@autonics.com

Türkiye

Autonics Otomasyon Ticaret Ltd. Sti.
T 90-216-365-9117/3/4 F 90-216-365-9112
E turkiye@autonics.com

Brazil

Autonics do Brasil Comercial Importadora
e Exportadora LTDA
T 55-11-2307-8480 / 3195-4610 F 55-11-2309-7784
E comercial@autonics.com.br

India

Autonics Automation India Private Limited
T 91-22-2768-2570
E india@autonics.net.in

Malaysia

Mal-Autonics Sensor Sdn. Bhd.
T 60-3-7805-7190 F 60-3-7805-7193
E malaysia@autonics.com

USA

Autonics USA, Inc.
T 1-847-680-8160 F 1-847-680-8155
E sales@autonicsusa.net

China

Autonics Electronic (Jiaxing) Corporation
T 86-573-8216-1900 F 86-573-8216-1917
E china@autonics.net

Indonesia

PT. Autonics Indonesia
T 62-21-8088-8814/5
E indonesia@autonics.co.id

Mexico

Autonics Mexico S.A. DE C.V
T 52-800-523-2131
E ventas05@autonics.com

Vietnam

Cong Ty TNHH Autonics Vina
T 84-28-3771-2662 F 84-28-3771-2663
E vietnam@autonics.com

Products

Sensors, Controllers, Motion Devices, Safety, Measuring Equipment, Connection Equipment and more

- Photoelectric Sensors • Photomicro Sensors • Fiber Optic Sensors • Displacement Sensors • LiDAR • Ultrasonic Sensors • Door Sensors
- Area Sensors • Proximity Sensors • Linear Positioning Sensors • Rotary Encoders • Temperature Sensors • Temperature Transmitters
- Pressure Sensors • Pressure Transmitters • Smart Camera • Vision Sensors • Safety Light Curtains • Safety Door Switches • Safety Switches
- Safety Controllers • Safety I/O Terminal Blocks • Temperature Controllers • Solid State Relays • Power Controllers • Counters • Timers
- Digital Panel Meters • Digital Display Units • Sensor Controllers • SMPS • Industrial PC • HMIs • Recorders • Indicators • Network Converters
- Closed Loop Stepper Motor System • 5-Phase Stepper Motor & Drivers • 2-Phase Stepper Motor Drivers • Motion Controllers
- Industrial Networking • I/O Terminal Blocks • Distribution Boxes • Cables • Control Switches / Pilot Lights / Buzzers • Software

* The dimensions or specifications on this product guide may change and some models may be discontinued without notice.

202512-VG2 Series Brochure-EN-01