

# Scanning Laser Range Finder

## Smart-URG Pro

### UST-30LCN

### Specification

CE  
RoHS

$\Delta \times 2$	Added the startup temperature conditions		P5	2023.07.12	<i>T.Kasahara</i> RS-02050
Symbol	Amended Reason		Pages	Date	Amended by Ref.No
Approved by	Checked by	Drawn by	Designed by	Title	UST-30LCN Specification
<i>M.Hino</i>	<i>A.Yamamoto</i>	<i>T.Kasahara</i>	<i>A.Yamamoto</i>	Drawing No.	C-42-04511 1/13

## 1. General

UST-30LCN is a sensor which scans a 270° field using a laser beam ( $\lambda = 905 \text{ nm}$ ), then calculates coordinates by measuring the distance to an object and its corresponding step angle (LX mode) and detects obstacles within the setting area (LA mode). Only LX mode supports the multi echo data output. In LA mode, selected single echo output data is available. The desired mode (LX or LA) can be selected in the configuration application.

### 1-2. Area configuration

The user can configure areas in the sensor using application software provided by the manufacturer. Install the software in a supported operating system and connect the sensor using an Ethernet cable. See section 7 for details on types of area configuration.

### 1-3. Area switching

The sensor has 5 external inputs for switching the area. Provide the correct signal states on these inputs (see Table 1) to switch the area. There are modes 1 and 2 in LA mode. Use mode 2 when using the motor synchronization function. However, the number of areas that can be set decrease.

### 1-4. Malfunction output

The sensor has a self-diagnostic function. It switches the malfunction output to an OFF state when errors are detected in the internal components.

## 2. Structure

### 2-1. Structure diagram

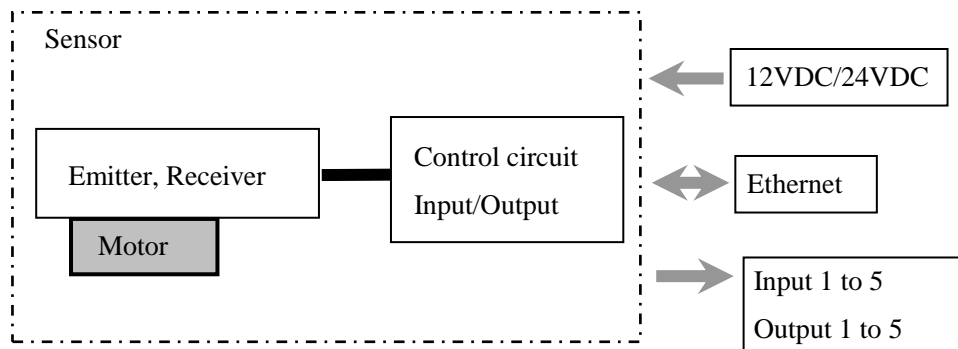

### 2-2. Laser scanning image

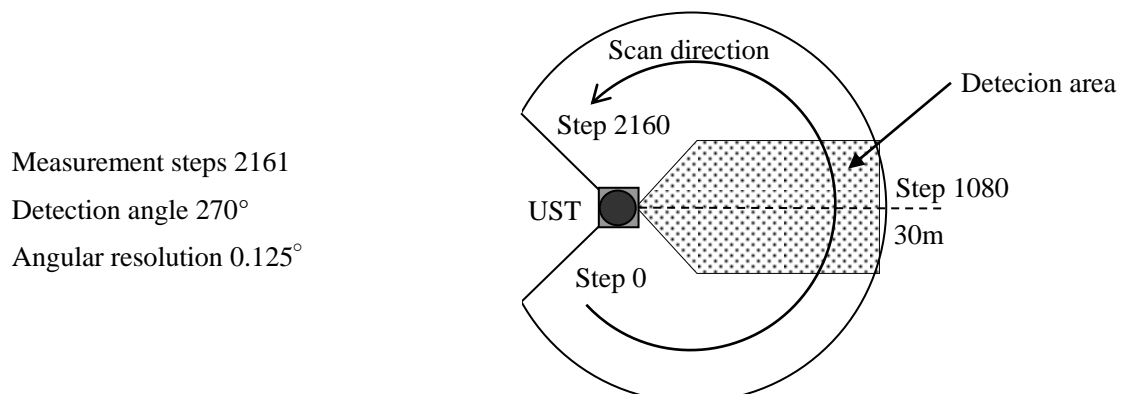

Title	UST-30LCN Specification	Drawing No	C-42-04511	2 / 13
-------	-------------------------	------------	------------	--------

### 3. Important notes

- (1) This sensor is not a safety device/tool.
- (2) This sensor cannot be used for human body detection as per the machinery directives.
- (3) Hokuyo products are not developed and manufactured for the use in weapons, equipments or related technologies intended for destroying human lives or causing mass destruction. If such possibilities or usages are revealed, the sales of Hokuyo products to those customers might be halted by the laws of Japan such as Foreign Exchange Law, Foreign Trade Law or Export Trade control order. In addition, Hokuyo products are for the purpose of maintaining the global peace and security in accordance with the above law of Japan.
- (4) Sensor emits laser for measurement. Sensor's operation may become unstable under the influence of strong interference light or when emitted lights are not reflected back from the object.
- (5) Sensor's operation may become unstable due to rain, snow and fog or due to dust pollution on the optical window.
- (6) Rules and regulations related to safety should be followed strictly when machine users and system designers operates the sensor.
- (7) Before using the sensor, please read carefully and understand this specification.

Title	UST-30LCN Specification	Drawing No	C-42-04511	3/13
-------	-------------------------	------------	------------	------

#### 4. Specifications

Product name	Scanning Laser Range Finder	
Model	UST-30LCN	
Supply voltage	12VDC/24VDC (operation range 10 to 30V ripple within 10%)	
Supply current(*1)	150mA or less (when using DC24V) (during start up 450mA is necessary.)	
Supply power	Less than 3.6 W(steady state)	
Light source	Laser semiconductor (905nm)	
Laser Safety	Class1 (IEC60825-1:2014)	
Detection range and object	0.05m to 30m(*2) (white kent sheet) 0.05m to 12m(*2) (diffuse reflectance 10%) Max. detection distance : 60m Min. detection size : 90mm(10m)、180mm(20m)、260mm(30m)	
Accuracy	±40mm (*2)	
Repeated accuracy	σ< 20mm (*2)	
Scan angle	270°	
Scan speed(*3)	25msec (motor speed 2400rpm)	
Angular resolution	0.125°	
Start up time	Within 10 sec (start up time differs if malfunction is detected during start up)	
Outputs	Photo-coupler, open collector output Max DC 30V 50mA Output 1: Output 1 OFF during object detection Output 2: Output 2 OFF during object detection Output 3: Output 3 OFF during object detection Malfunction output: ON during normal operation, OFF during malfunction Synchronous output : Synchronization signal during Master/Slave operation. Note: Output 1 to 3 are switched OFF during malfunction state	
Inputs	Photo-coupler, common anode, power supply is 4mA when input is ON Input 1 to 5: Area switching inputs (refer Table1)	
Output response time (*4)	OFF	66msec to 3241msec
	ON	66msec to 3241msec
Interface	Ethernet 100BASE-TX	
LED display	LX mode Power supply LED display (blue): Blinks during start up and malfunction state. LA mode Blue LED: ON during normal operation, blink during the start up, configuration and malfunction state Orange LED 1: Output 1 ON during object detection Orange LED 2: Output 2 ON during object detection Orange LED 3: Output 3 ON during object detection	
Synchronization function (*5)	Synchronization Master/Slave operation mode (can set by using Area Designer) Synchronization slave mode(0° ) Synchronization slave mode(90° ) Synchronization slave mode(180° ) Synchronization slave mode(270° )	

Title	UST-30LCN Specification	Drawing No	C-42-04511	4 / 13
-------	-------------------------	------------	------------	--------

#### 4. Specifications

Surrounding intensity	Less than 100,000lx Note : Avoid direct sunlight or other illumination sources as it may cause sensor malfunction
Ambient temperature and humidity	-30°C to +50°C (*7) , below 85%RH (without dew, frost) $\hat{A}$
Storage temperature and humidity	-30°C to +70°C, below 85%RH (without dew, frost)
Vibration resistance	10 to 55Hz double amplitude of 1.5mm for 2hrs in each X, Y, and Z direction 55 to 200Hz 98m/s <sup>2</sup> sweep of 2min for 1hr in each X,Y and Z direction
Shock resistance	196m/s <sup>2</sup> (20G) X,Y and Z direction each 10 times
Insulation resistance	10MΩ
EMC standards	(EMI) EN61326-1:2013 EN55011:2009 + A1:2010 (EMS) EN61326-1:2013 EN61000-4-2:2009 EN61000-4-3:2006 + A1:2008 + A2:2010 EN61000-4-4:2012 EN61000-4-6:2014 EN61000-4-8:2010
RoHS	(EU)2015/863
Protective Structure	IP67(*6)
Weight	130g (excluding cable)
Material	Front case: Polycarbonate, Rear case: Aluminum
Dimensions(W×D×H)	50×50×70mm (sensor only)

(\*1) Please use a power supply with enough current capacity.

(\*2) Under the factory standard testing conditions using white kent sheet.

In the low temperature environment of -11°C or below, the detection distance will be as below.

white kent sheet: 0.05m to 25m, diffuse reflectance 10% : 0.05m to 8m

(\*3) In the case of using other command than MD,MS and ME. There is possibility of delay in response speed, due to surrounding environment.

(\*4) Initial setting is 66msec. ON/OFF delay function switching is possible by Area Designer. Response time can be further delayed by a maximum of 1scan during the area switching.

(\*5) Initial setting is synchronization master. When using synchronization operation, refer to section 9 for details about synchronization wiring. Synchronization slave setting is possible using Area Designer.

(\*6) The protective structure of Ethernet and Power connector is not IP67.

(\*7) The startup temperature is -10°C to +50°C.  $\hat{A}$

Title	UST-30LCN Specification	Drawing No	C-42-04511	5 / 13
-------	-------------------------	------------	------------	--------

Table 1: Input states and corresponding area number

[Input 1]	[Input 2]	[Input 3]	[Input 4]	[Input 5]	Area Number*2
ON	ON	ON	ON	ON	Laser off*1
OFF	ON	ON	ON	ON	Area1
ON	OFF	ON	ON	ON	Area2
OFF	OFF	ON	ON	ON	Area3
ON	ON	OFF	ON	ON	Area4
OFF	ON	OFF	ON	ON	Area5
ON	OFF	OFF	ON	ON	Area6
OFF	OFF	OFF	ON	ON	Area7
ON	ON	ON	OFF	ON	Area8
OFF	ON	ON	OFF	ON	Area9
ON	OFF	ON	OFF	ON	Area10
OFF	OFF	ON	OFF	ON	Area11
ON	ON	OFF	OFF	ON	Area12
OFF	ON	OFF	OFF	ON	Area13
ON	OFF	OFF	OFF	ON	Area14
OFF	OFF	OFF	OFF	ON	Area15
ON	ON	ON	ON	OFF	Area16
OFF	ON	ON	ON	OFF	Area17
ON	OFF	ON	ON	OFF	Area18
OFF	OFF	ON	ON	OFF	Area19
ON	ON	OFF	ON	OFF	Area20
OFF	ON	OFF	ON	OFF	Area21
ON	OFF	OFF	ON	OFF	Area22
OFF	OFF	OFF	ON	OFF	Area23
ON	ON	ON	OFF	OFF	Area24
OFF	ON	ON	OFF	OFF	Area25
ON	OFF	ON	OFF	OFF	Area26
OFF	OFF	ON	OFF	OFF	Area27
ON	ON	OFF	OFF	OFF	Area28
OFF	ON	OFF	OFF	OFF	Area29
ON	OFF	OFF	OFF	OFF	Area30
OFF	OFF	OFF	OFF	OFF	Area31

\*1 : Laser is switched off when all inputs (1 to 5) are ON.

\*2 : When using the synchronization function in LA mode 2, the maximum area number will be 15.

Title	UST-30LCN Specification	Drawing No	C-42-04511	6 / 13
-------	-------------------------	------------	------------	--------

## 5. Connection

### 5-1. Power source, I/O cable

connector : DF62B-24EP-2.2C(00) Hirose

Cable length: 1000mm

Keep the output wires open or connect to output “Com Output -“ if not in use.

Keep the input wires open or connect to output “Com Input +“ if not in use.

The input and output directions are based on this product.

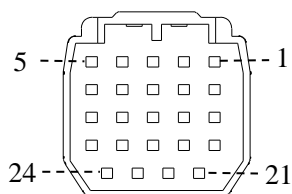

Short point 1 : [mm]

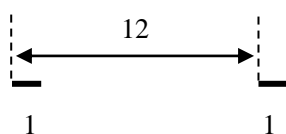

Short point 2 :

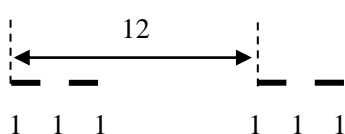

Number	Color	Signal
1	Orange(Red short point 1)	+VIN (DC12V/DC24V)
2	Orange(Black short point 1)	-VIN
3	Gray(Red short point 1)	Output 1
4	Gray(Black short point 1)	Output 2
5	White(Red short point 1)	Output 3
6	White(Black short point 1)	Malfunction output
7	Yellow(Red short point 1)	Synchronous output
8	Yellow(Black short point 1)	COM Output -
9	Pink(Red short point 1)	COM Input +
10	Pink(Black short point 1)	Input 1
11	Orange(Red short point 2)	Input 2
12	Orange(Black short point 2)	Input 3
13	Gray(Red short point 2)	Input 4
14	Gray(Black short point 2)	Input 5/ Synchronous input
15	NC	NC
16	NC	NC
17	NC	NC
18	NC	NC
19	NC	NC
20	NC	NC
21	NC	NC
22	NC	NC
23	NC	NC
24	NC	NC

### 5-2. Ethernet cable

Cable length: 300mm

Color	Signal
White(Orange)	TX+
Orange	TX-
White(Green)	RX+
Green	RX-

## 6. LED display

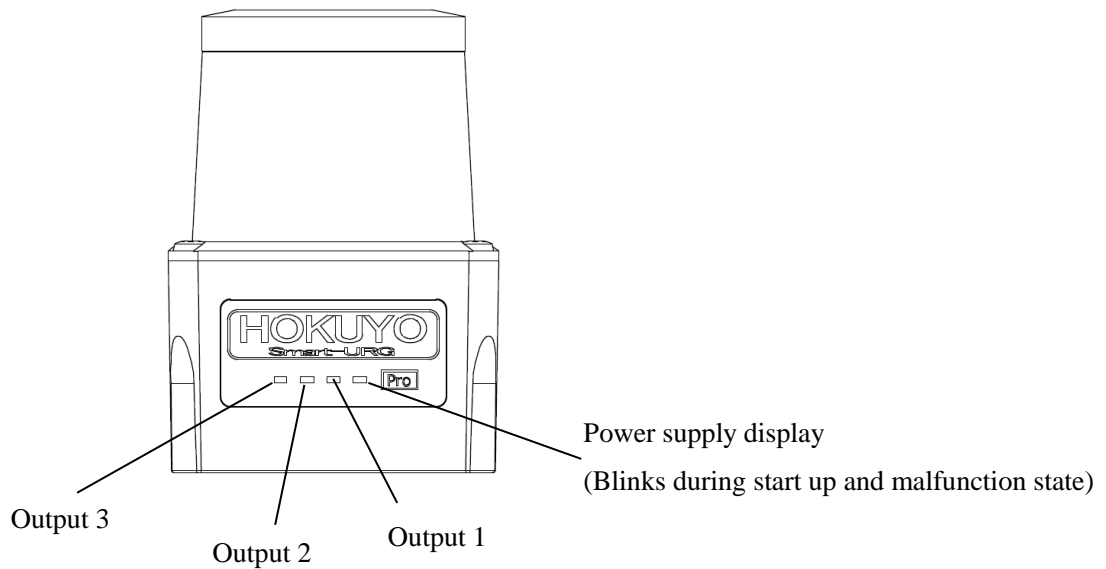

## 7. Area configuration

### 7-1 Normal configuration

In the normal configuration, the area for Output 1 is configured first and the shape of it can be configured freely. Areas for Output 2 and Output 3 are dependent on the set area of Output 1 and therefore they are configured inside it. The shapes of Output 2 and Output 3 areas can be straight, fan shape or ratio (Figure 1).

Figure 2 and Table 2 show the relationship between the detected object position and the output states.

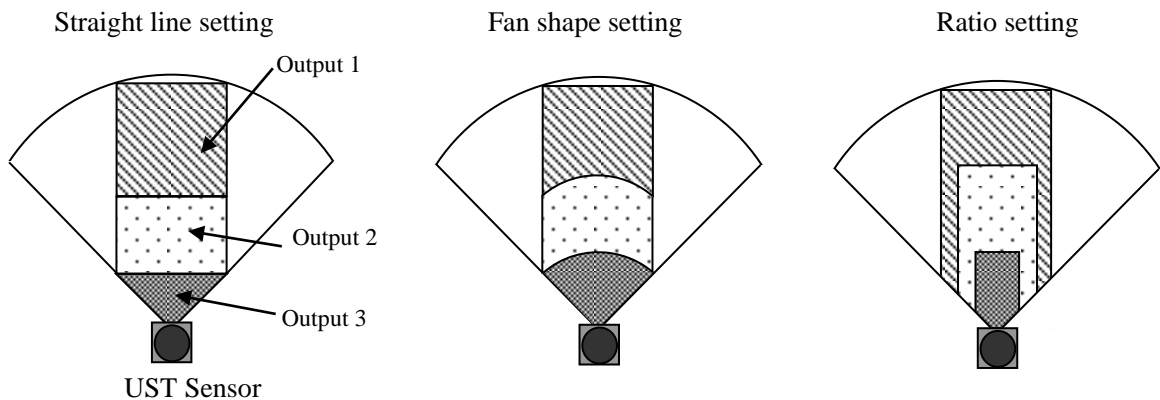

Figure 1: Normal area configuration

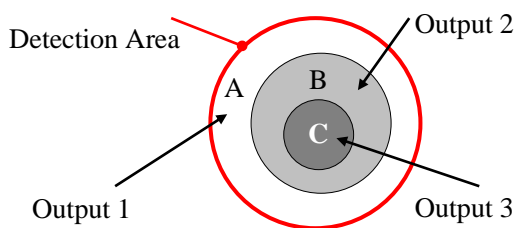

Figure 2: Output areas

Object position	Output 1	Output 2	Output 3
A	OFF	ON	ON
B	OFF	OFF	ON
C	OFF	OFF	OFF

Table 2: Relationship between object position and output states



## 7-2. Independent configuration

In the independent configuration, areas for Output 1, Output 2 and Output 3 can be configured freely. The field covered by each output can be completely separate from the other output areas or there can be an overlapping region between the output areas Figure 3 (a) and (b).

Figure 4 and Table 3 show the relationship between the object position and the output states.

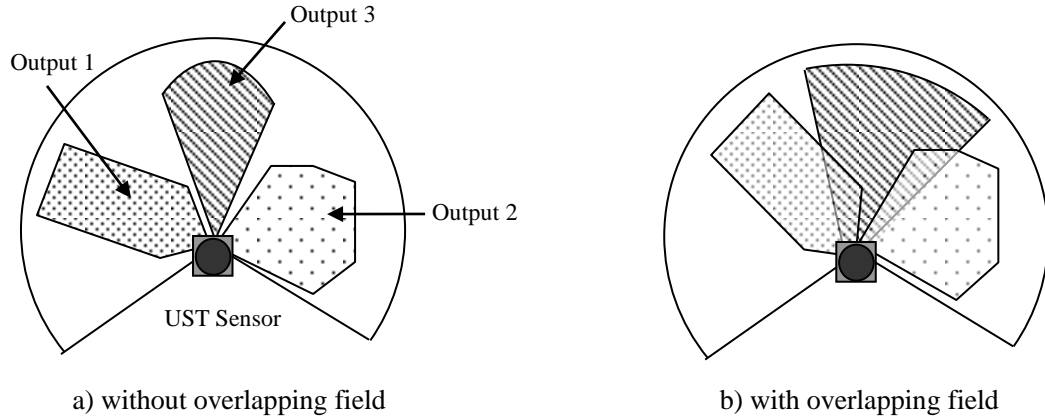

Figure 3: Independent area configuration

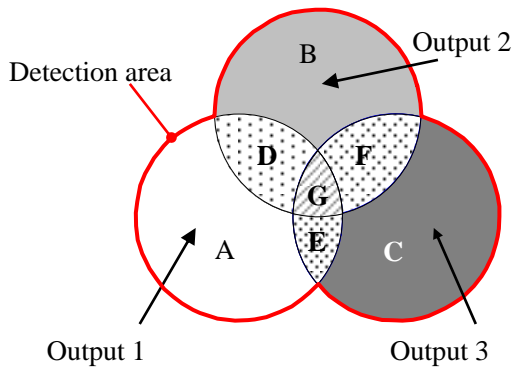

Figure 4: Output areas

Object position	Output 1	Output 2	Output 3
A	OFF	ON	ON
B	ON	OFF	ON
C	ON	ON	OFF
D	OFF	OFF	ON
E	OFF	ON	OFF
F	ON	OFF	OFF
G	OFF	OFF	OFF

Table 3: Relationship between object position and output area

Title	UST-30LCN Specification	Drawing No	C-42-04511	9/13
-------	-------------------------	------------	------------	------

### 8. Input/Output circuit connection example

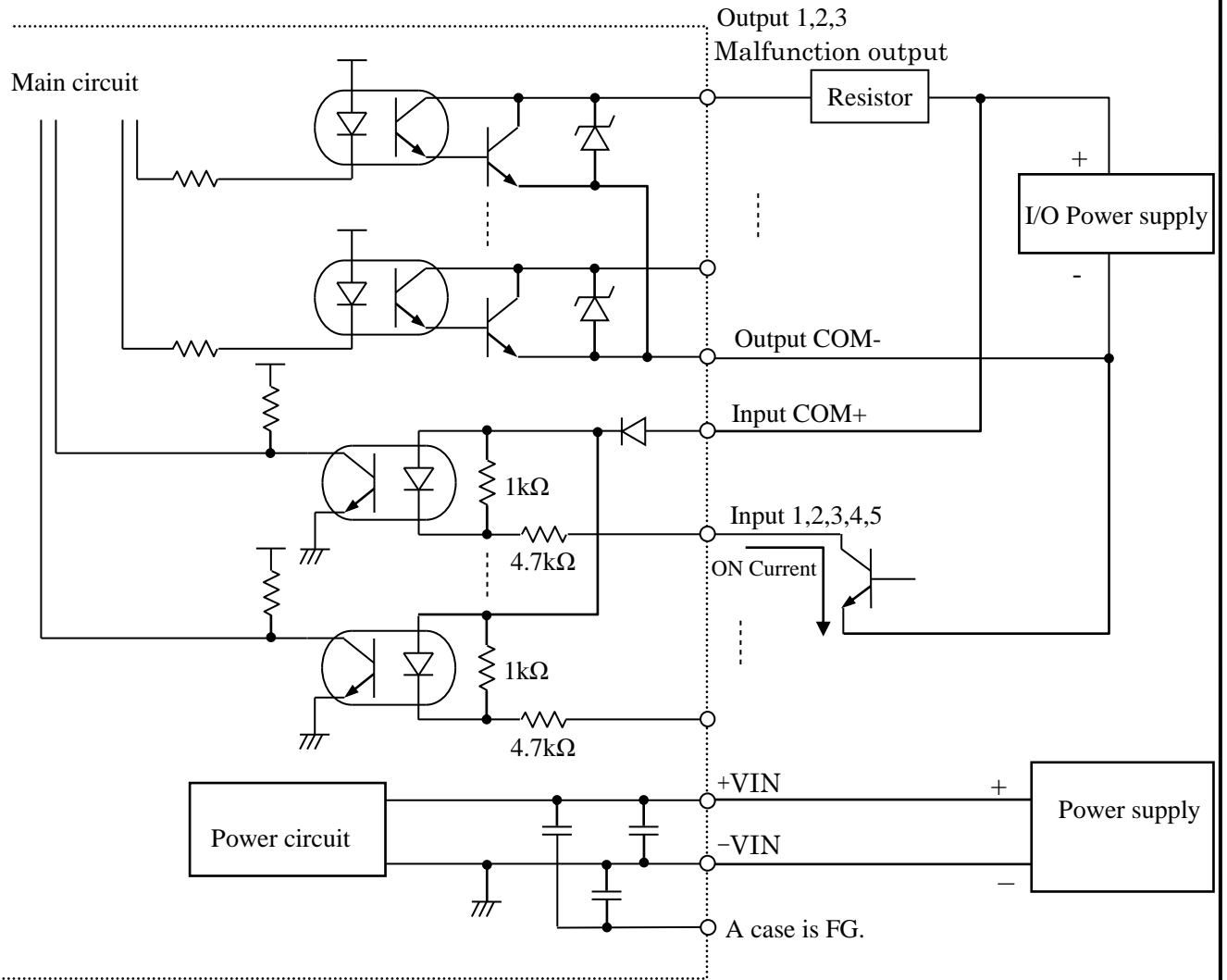
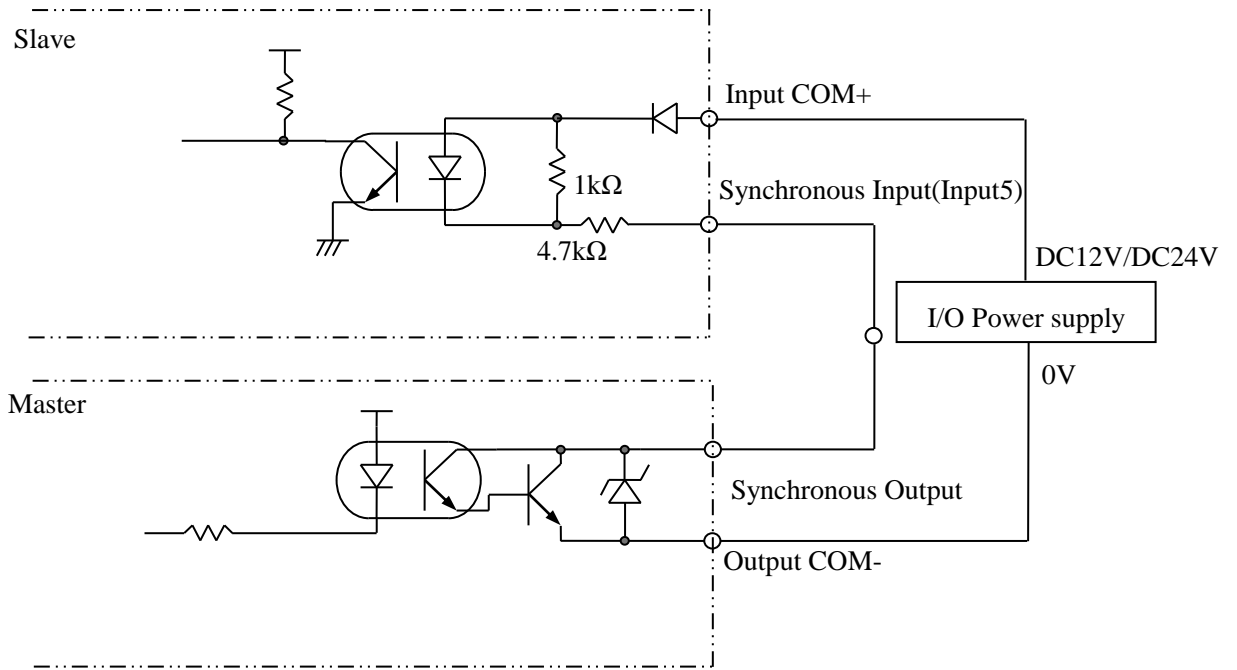

Figure 5: Connection example of inputs, outputs and power supply

Title	UST-30LCN Specification	Drawing No	C-42-04511	10 / 13
-------	-------------------------	------------	------------	---------

### 9. The example of Synchronous wiring



Note: This function is available in LA mode 2.

Title	UST-30LCN Specification	Drawing No	C-42-04511	11 / 13
-------	-------------------------	------------	------------	---------

## 10. Measurement Data

Distance Value (x)	Meaning
$x < 10$	Output numerical number "65534" as Measurement error
$10 \leq x \leq 60000$	Valid distance [mm]
$x > 60000$	Output numerical number "65533" as Measurement error (object does not exist or object has low reflectivity)

## 11. Control signal

### 11-1. Synchronous output

1 pulse is approximately 1ms. Output signal synchronization timing chart is shown as below.

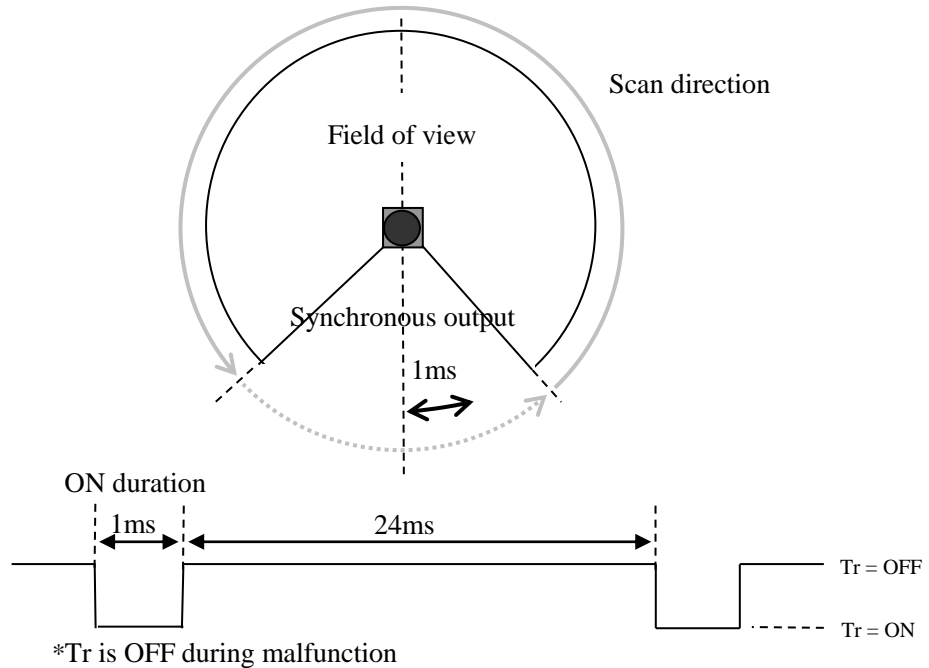

## 12. Multi-echo function

This sensor provides a maximum of three echo (1<sup>st</sup>, 2<sup>nd</sup>, last) for each step (one direction). It also provides distance value and level value for each step. (For LX mode only)

Multiple echo are generated when the laser beam is split by reflection on surface of transparent objects, reflection on object's edge and reflection from small particles such as rain, mist, dust and fog. Thus, distance and level value obtained from the multiple reflections in the same direction is called multi echo. However, if the distance between two object is too close or the object has low reflectance, the sensor may not detect it as multi echo.

Title	UST-30LCN Specification	Drawing No	C-42-04511	12 / 13
-------	-------------------------	------------	------------	---------

### 13. Ethernet Setting

1. The setting value is as below.

IP Initial value :192.168.0.10

Port number :10940

2. About changing IP address

It is possible to change and reset the IP address using a specialized application (IP Discovery).

For details on installation and operation of IP Discovery, Please refer to IP discovery manual. (C-41-02603)

### 14. Cautions for operation

This sensor uses high speed processing components that generate heat during operation.

The heat is concentrated at the bottom of the unit. When mounting, please attach the bottom of the unit to a good heat sink. A 200mm x 200mm x 2mm aluminum plate is recommended as a heat sink.

If multiple sensors are installed side by side, a sensor might mistake the laser pulses of other units as its own and the detection error occurs. When it happens, usually the error lasts for one or two steps of measurement. Please use software filters to handle this type of error.

Title	UST-30LCN Specification	Drawing No	C-42-04511	13 / 13
-------	-------------------------	------------	------------	---------